

Features

- Central office quality DTMF transmitter/receiver
- Low voltage operation (2.7-3.6V)
- Pin for pin compatible with existing MT8880, MT8888 and MT8889 devices
- Adaptive micro interface enables compatibility with Intel and Motorola processors
- DTMF transmitter/receiver power down via register control
- Adjustable guard time
- Automatic tone burst mode
- Call progress tone detection to -30dBm

Applications

- Credit card systems
- Paging systems
- Repeater systems/mobile radio
- Interconnect dialers
- Pay phones
- Remote monitor/Control systems

Ordering Information

MT88L89AE	20 Pin Plastic DIP
MT88L89AS	20 Pin SOIC
MT88L89AN	24 Pin SSOP
MT88L89AP	28 Pin PLCC

-40°C to +85°C
Description

The MT88L89 is a monolithic DTMF transceiver with call progress filter. It is fabricated in CMOS technology offering low power consumption and high reliability.

The receiver section is based upon the industry standard MT8870 DTMF receiver while the transmitter utilizes a switched capacitor D/A converter for low distortion, high accuracy DTMF signalling. Internal counters provide a burst mode such that tone bursts can be transmitted with precise timing. A call progress filter can be selected allowing a microprocessor to analyze call progress tones.

The MT88L89 utilizes an adaptive micro interface, which allows the device to be connected to a number of popular microcontrollers with minimal external logic. The MT88L89 provides enhanced power down features. The transmitter and receiver may independently be powered down via register control.

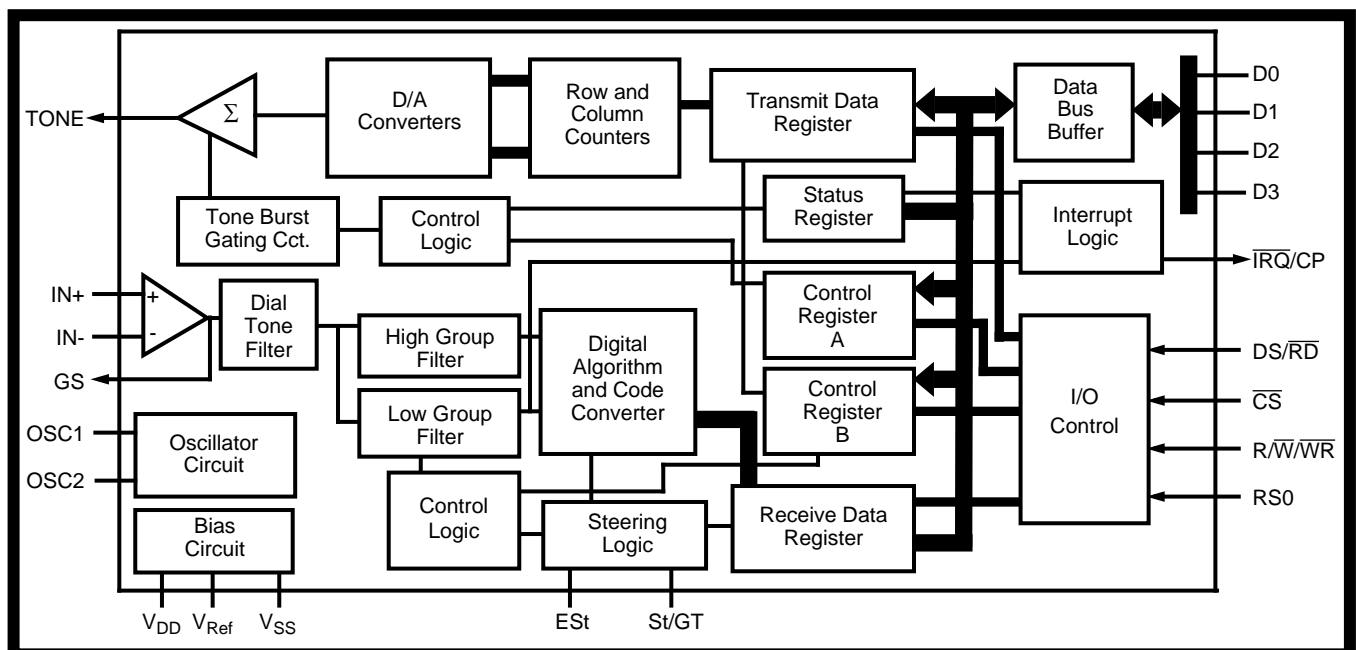
Figure 1 - Functional Block Diagram

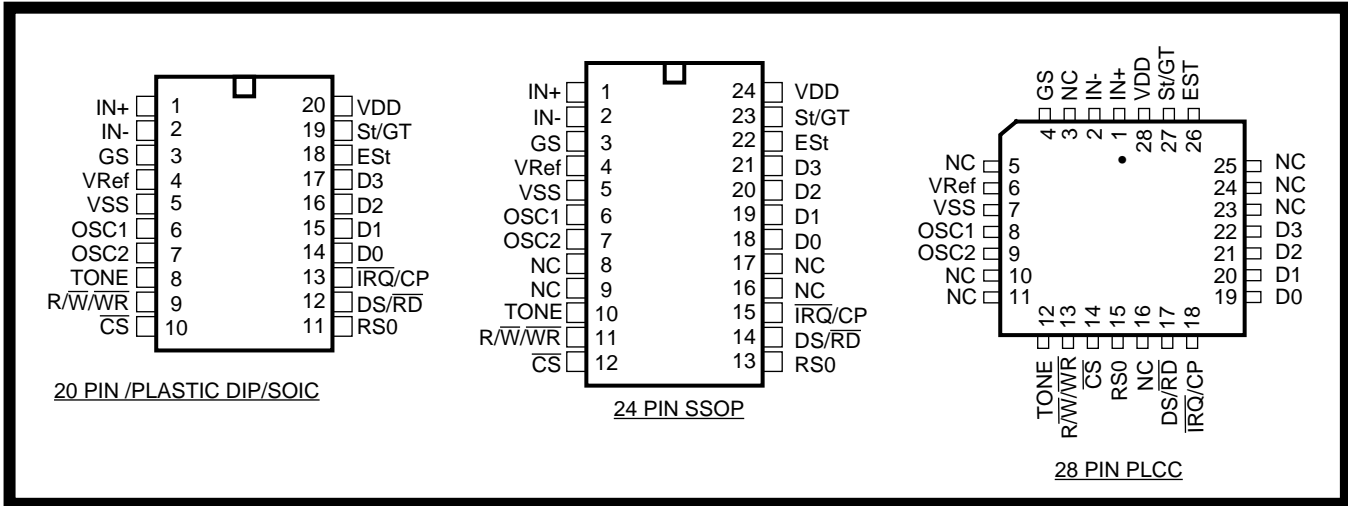

Figure 2 - Pin Connections

Pin Description

Pin #			Name	Description
20	24	28		
1	1	1	IN+	Non-inverting op-amp input.
2	2	2	IN-	Inverting op-amp input.
3	3	4	GS	Gain Select . Gives access to output of front end differential amplifier for connection of feedback resistor.
4	4	6	V _{Ref}	Reference Voltage output (V _{DD} /2).
5	5	7	V _{SS}	Ground (0V).
6	6	8	OSC1	Oscillator input. This pin can also be driven directly by an external clock. CMOS compatible.
7	7	9	OSC2	Oscillator output. A 3.579545 MHz crystal connected between OSC1 and OSC2 completes the internal oscillator circuit. Leave open circuit when OSC1 is driven externally.
8	10	12	TONE	Output from internal DTMF transmitter. High impedance when TOUT bit in CRA register is set to low. Requires resistive termination to V _{SS} .
9	11	13	R/W (WR)	(Motorola) Read/Write or (Intel) Write microprocessor input. CMOS compatible.
10	12	14	CS	Chip Select input must be gated externally by either address strobe (AS), valid memory address (VMA) or address latch enable (ALE) signal, depending on processor used. See Figure 12. Must not be tied low. CMOS compatible.
11	13	15	RS0	Register Select input. Refer to Table 3 for bit interpretation. CMOS compatible.
12	14	17	DS (RD)	(Motorola) Data Strobe or (Intel) Read microprocessor input. Activity on this input is only required when the device is being accessed. CMOS compatible.
13	15	18	IRQ/CP	Interrupt Request/Call Progress (open drain) output. In interrupt mode, this output goes low when a valid DTMF tone burst has been transmitted or received. In call progress mode, this pin will output a rectangular signal representative of the input signal applied at the input op-amp. The input signal must be within the bandwidth limits of the call progress filter, see Figure 8.
14-17	18-21	19-22	D0-D3	Microprocessor data bus. High impedance when CS = 1 or DS = 0 (Motorola) or RD = 1 (Intel). CMOS compatible.
18	22	26	Est	Early Steering output. Presents a logic high once the digital algorithm has detected a valid tone pair (signal condition). Any momentary loss of signal condition will cause Est to return to a logic low.

Pin Description

Pin #			Name	Description
20	24	28		
19	23	27	St/GT	Steering Input/Guard Time output (bidirectional). A voltage greater than V_{TSt} detected at St causes the device to register the detected tone pair and update the output latch. A voltage less than V_{TSt} frees the device to accept a new tone pair. The GT output acts to reset the external steering time-constant; its state is a function of ESt and the voltage on St.
20	24	28	V_{DD}	Positive power supply (3V typ.).
	8,9 16, 17	3,5, 10-11 16 23- 25	NC	No Connection.

Functional Description

The MT88L89 Integrated DTMF Transceiver consists of a high performance DTMF receiver with an internal gain setting amplifier and a DTMF generator, which employs a burst counter to synthesize precise tone bursts and pauses. A call progress mode can be selected so that frequencies within the specified passband can be detected. The adaptive micro interface allows various microcontrollers to access the MT88L89 internal registers.

Power Down

The MT88L89 provides enhanced power down functionality to facilitate minimization of supply current consumption. DTMF transmitter and receiver circuit blocks may be independently powered down via register control. When asserted, RxEN control bit powers down all analog and digital circuitry associated solely with the DTMF and Call Progress receiver. The TOUT control bit is used to disable the transmitter and put all circuitry associated only with the DTMF transmitter in power down mode. With the TOUT control bit is set to zero, the TONE output pin is held in a high impedance (floating) state. When both transmitter and receiver circuits are powered down, circuits utilized by both the DTMF transmitter and receiver are also powered down. This includes the crystal oscillator, and the V_{Ref} generator. In addition, the \overline{IRQ} , TONE output and DATA pins are held in a high impedance state.

Input Configuration

The input arrangement of the MT88L89 provides a differential-input operational amplifier as well as a bias source (V_{Ref}), which is used to bias the inputs at $V_{DD}/2$. Provision is made for connection of a feedback resistor to the op-amp output (GS) for gain adjustment. In a single-ended configuration, the input pins are connected as shown in Figure 3.

Figure 4 shows the necessary connections for a differential input configuration.

Receiver Section

Separation of the low and high group tones is achieved by applying the DTMF signal to the inputs of two sixth-order switched capacitor bandpass filters, the bandwidths of which correspond to the low and high group frequencies (see Table 1). The filters also incorporate notches at 350 Hz and 440 Hz for exceptional dial tone rejection. Each filter output is followed by a single order switched capacitor filter section, which smooths the signals prior to limiting. Limiting is performed by high-gain comparators which are provided with hysteresis to prevent detection of unwanted low-level signals. The outputs of the comparators provide full rail logic swings at the frequencies of the incoming DTMF signals.

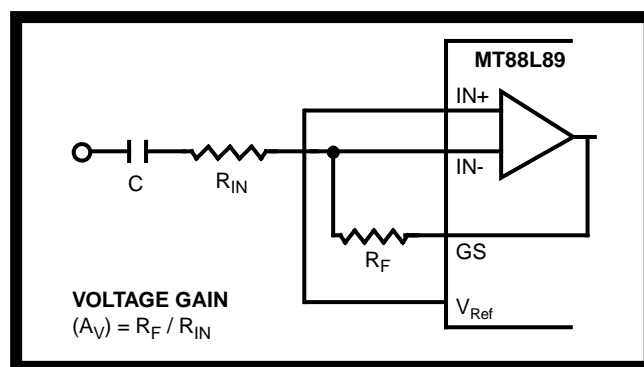

Figure 3 - Single-Ended Input Configuration

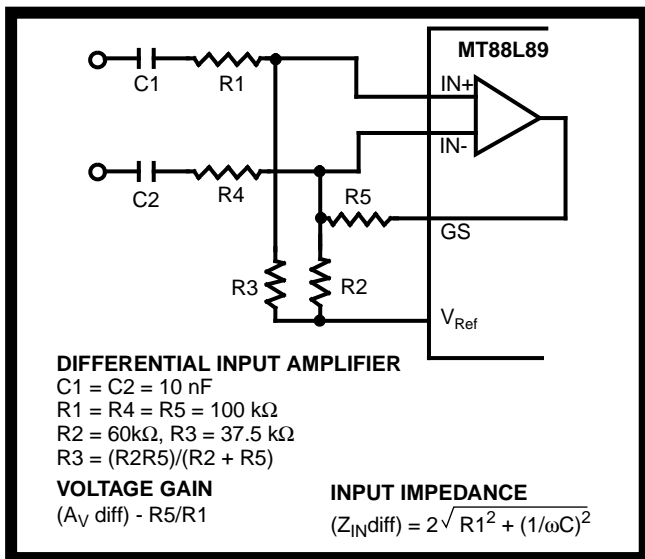

Figure 4 - Differential Input Configuration

F _{LOW}	F _{HIGH}	DIGIT	D ₃	D ₂	D ₁	D ₀
697	1209	1	0	0	0	1
697	1336	2	0	0	1	0
697	1477	3	0	0	1	1
770	1209	4	0	1	0	0
770	1336	5	0	1	0	1
770	1477	6	0	1	1	0
852	1209	7	0	1	1	1
852	1336	8	1	0	0	0
852	1477	9	1	0	0	1
941	1336	0	1	0	1	0
941	1209	*	1	0	1	1
941	1477	#	1	1	0	0
697	1633	A	1	1	0	1
770	1633	B	1	1	1	0
852	1633	C	1	1	1	1
941	1633	D	0	0	0	0

0= LOGIC LOW, 1= LOGIC HIGH

Table 1. Functional Encode/Decode Table

Following the filter section is a decoder employing digital counting techniques to determine the frequencies of the incoming tones and to verify that they correspond to standard DTMF frequencies. A complex averaging algorithm protects against tone simulation by extraneous signals such as voice while providing tolerance to small frequency deviations and variations. This averaging algorithm has been developed to ensure an optimum combination of immunity to talk-off and tolerance to the presence of

interfering frequencies (third tones) and noise. When the detector recognizes the presence of two valid tones (this is referred to as the “signal condition” in some industry specifications) the “Early Steering” (ESt) output will go to an active state. Any subsequent loss of signal condition will cause ESt to assume an inactive state.

Steering Circuit

Before registration of a decoded tone pair, the receiver checks for a valid signal duration (referred to as character recognition condition). This check is performed by an external RC time constant driven by ESt. A logic high on ESt causes v_c (see Figure 5) to rise as the capacitor discharges. Provided that the signal condition is maintained (ESt remains high) for the validation period (t_{GTP}), v_c reaches the threshold (V_{TSt}) of the steering logic to register the tone pair, latching its corresponding 4-bit code (see Table 1) into the Receive Data Register. At this point the GT output is activated and drives v_c to V_{DD} . GT continues to drive high as long as ESt remains high. Finally, after a short delay to allow the output latch to settle, the delayed steering output flag goes high, signalling that a received tone pair has been registered. The status of the delayed steering flag can be monitored by checking the appropriate bit in the status register. If Interrupt mode has been selected, the $\overline{IRQ/CP}$ pin will pull low when the delayed steering flag is active.

The contents of the output latch are updated on an active delayed steering transition. This data is presented to the four bit bidirectional data bus when the Receive Data Register is read. The steering circuit works in reverse to validate the interdigit pause between signals. Thus, as well as rejecting signals too short to be considered valid, the receiver will tolerate signal interruptions (drop out) too short to be considered a valid pause. This facility, together with the capability of selecting the steering time constants externally, allows the designer to tailor performance to meet a wide variety of system requirements.

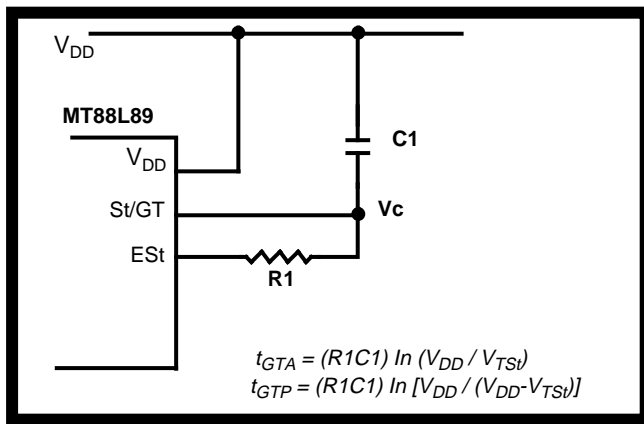

Figure 5 - Basic Steering Circuit

Guard Time Adjustment

The simple steering circuit shown in Figure 5 is adequate for most applications. Component values are chosen according to the following inequalities (see Figure 7):

$$t_{REC} \geq t_{DPmax} + t_{GTPmax} - t_{DAmin}$$

$$t_{REC} \leq t_{DPmin} + t_{GTPmin} - t_{DAmax}$$

$$t_{ID} \geq t_{DAmax} + t_{GTAmx} - t_{DPmin}$$

$$t_{DO} \leq t_{DAmin} + t_{GTAmn} - t_{DPmax}$$

The value of t_{DP} is a device parameter (see AC Electrical Characteristics) and t_{REC} is the minimum signal duration to be recognized by the receiver. A value for C1 of 0.1 μ F is recommended for most

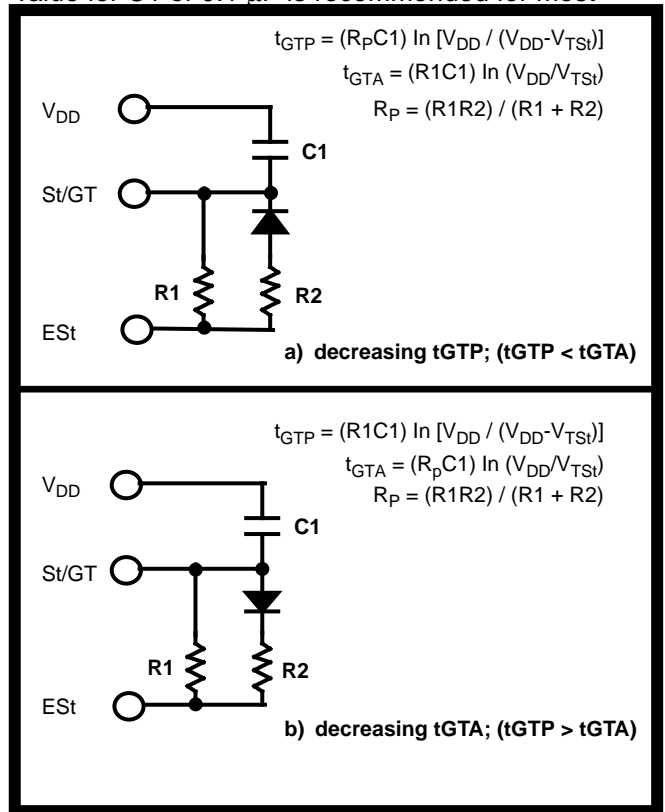

Figure 6 - Guard Time Adjustment

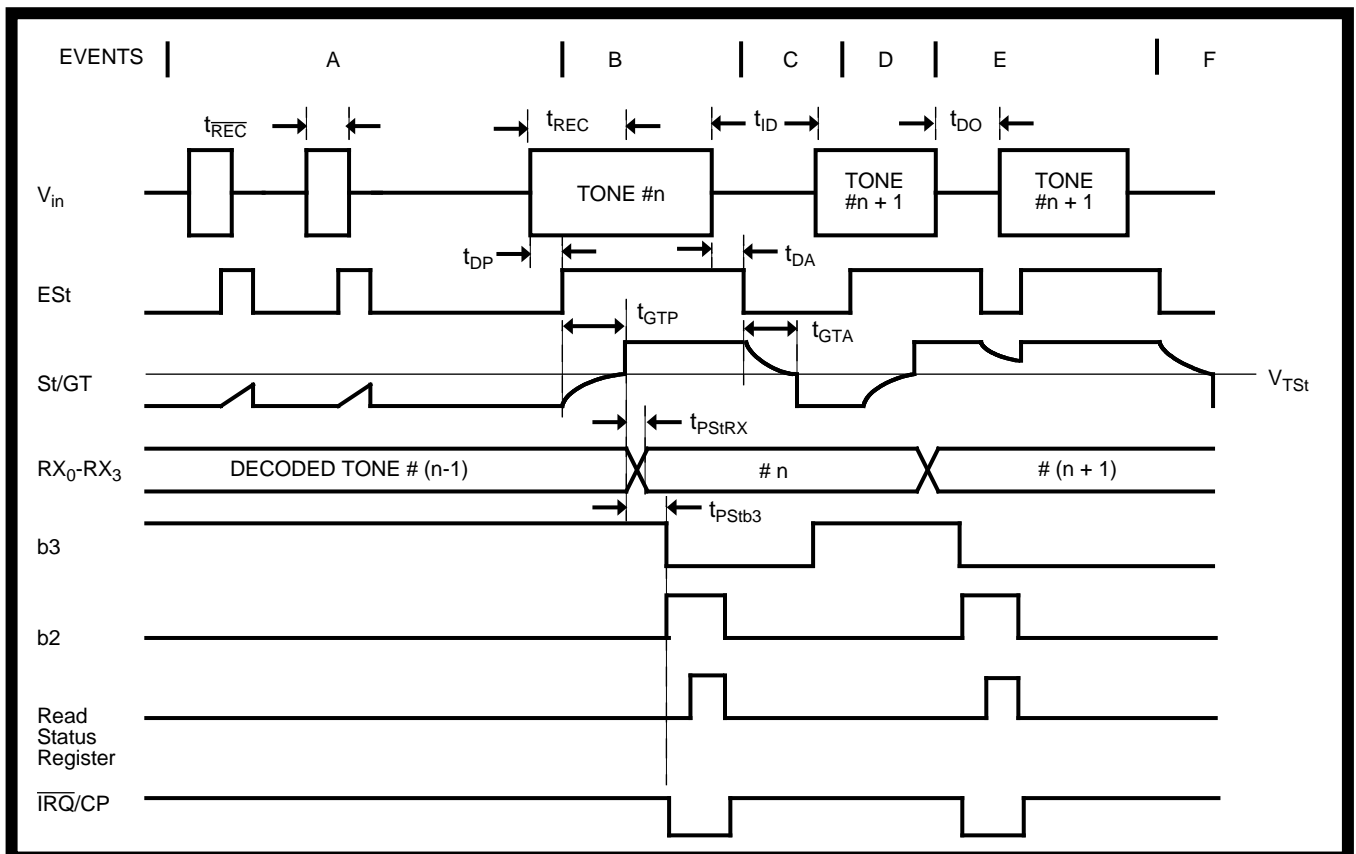

Figure 7 - Receiver Timing Diagram

EXPLANATION OF EVENTS	
A)	TONE BURSTS DETECTED, TONE DURATION INVALID, RX DATA REGISTER NOT UPDATED.
B)	TONE #n DETECTED, TONE DURATION VALID, TONE DECODED AND LATCHED IN RX DATA REGISTER.
C)	END OF TONE #n DETECTED, TONE ABSENT DURATION VALID, INFORMATION IN RX DATA REGISTER RETAINED UNTIL NEXT VALID TONE PAIR.
D)	TONE #n+1 DETECTED, TONE DURATION VALID, TONE DECODED AND LATCHED IN RX DATA REGISTER.
E)	ACCEPTABLE DROPOUT OF TONE #n+1, TONE ABSENT DURATION INVALID, DATA REMAINS UNCHANGED.
F)	END OF TONE #n+1 DETECTED, TONE ABSENT DURATION VALID, INFORMATION IN RX DATA REGISTER RETAINED UNTIL NEXT VALID TONE PAIR.
EXPLANATION OF SYMBOLS	
V_{in}	DTMF COMPOSITE INPUT SIGNAL.
ES _t	EARLY STEERING OUTPUT. INDICATES DETECTION OF VALID TONE FREQUENCIES.
St/GT	STEERING INPUT/GUARD TIME OUTPUT. DRIVES EXTERNAL RC TIMING CIRCUIT.
RX ₀ -RX ₃	4-BIT DECODED DATA IN RECEIVE DATA REGISTER
b3	DELAYED STEERING IN STATUS REGISTER (BIT 3) INDICATES THAT VALID FREQUENCIES HAVE BEEN PRESENT/ABSENT FOR THE REQUIRED GUARD TIME THUS CONSTITUTING A VALID SIGNAL. ACTIVE LOW FOR THE DURATION OF A VALID DTMF SIGNAL.
b2	RECEIVE DATA REGISTER FULL (BIT 2) IN STATUS REGISTER INDICATES THAT VALID DATA IS IN THE RECEIVE DATA REGISTER. THE BIT IS CLEARED AFTER THE STATUS REGISTER IS READ.
\overline{IRQ}/CP	INTERRUPT IS ACTIVE INDICATING THAT NEW DATA IS IN THE RX DATA REGISTER. THE INTERRUPT IS CLEARED AFTER THE STATUS REGISTER IS READ.
t_{REC}	MAXIMUM DTMF SIGNAL DURATION NOT DETECTED AS VALID. TYPICALLY 20MS.
t_{REC}	MINIMUM DTMF SIGNAL DURATION REQUIRED FOR VALID RECOGNITION. TYPICALLY 40MS.
t_{ID}	MINIMUM TIME BETWEEN VALID SEQUENTIAL DTMF SIGNALS. TYPICALLY 40MS.
t_{DO}	MAXIMUM ALLOWABLE DROPOUT DURING VALID DTMF SIGNAL. TYPICALLY 20MS.
t_{DP}	TIME TO DETECT VALID FREQUENCIES PRESENT.
t_{DA}	TIME TO DETECT VALID FREQUENCIES ABSENT.
t_{GTP}	GUARD TIME, TONE PRESENT.
t_{GTA}	GUARD TIME, TONE ABSENT.

Figure 9 - Description of Timing Events

applications, leaving R1 to be selected by the designer. Different steering arrangements may be used to select independent tone present (t_{GTP}) and tone absent (t_{GTA}) guard times. This may be necessary to meet system specifications which place both accept and reject limits on tone duration and interdigital pause. Guard time adjustment also allows the designer to tailor system parameters such as talk off and noise immunity.

Increasing t_{REC} improves talk-off performance since it reduces the probability that tones simulated by speech will maintain a valid signal condition long enough to be registered. Alternatively, a relatively short t_{REC} with a long t_{DO} would be appropriate for extremely noisy environments where fast acquisition time and immunity to tone drop-outs are required. Design information for guard time adjustment is shown in Figure 6. The receiver timing is shown in Figure 7 with a description of the events in Figure 9.

Call Progress Filter

A call progress mode, using the MT88L89, can be selected allowing the detection of various tones, which identify the progress of a telephone call on the network. The call progress tone input and DTMF

input are common, however, call progress tones can only be detected when CP mode has been selected. DTMF signals cannot be detected if CP mode has been selected (see Table 7). Figure 8 indicates the useful detect bandwidth of the call progress filter. Frequencies presented to the input, which are within the 'accept' bandwidth limits of the filter, are hard-limited by a high gain comparator with the \overline{IRQ}/CP pin serving as the output. The squarewave output obtained from the schmitt trigger can be analyzed by a microprocessor or counter arrangement to determine the nature of the call progress tone being detected. Frequencies which are in the 'reject' area will not be detected and consequently the \overline{IRQ}/CP pin will remain low.

DTMF Generator

The DTMF transmitter employed in the MT88L89 is capable of generating all sixteen standard DTMF tone pairs with low distortion and high accuracy. All frequencies are derived from an external 3.579545 MHz crystal. The sinusoidal waveforms for the individual tones are digitally synthesized using row and column programmable dividers and switched capacitor D/A converters. The row and column tones are mixed and filtered providing a DTMF signal with low total harmonic distortion and high accuracy. To

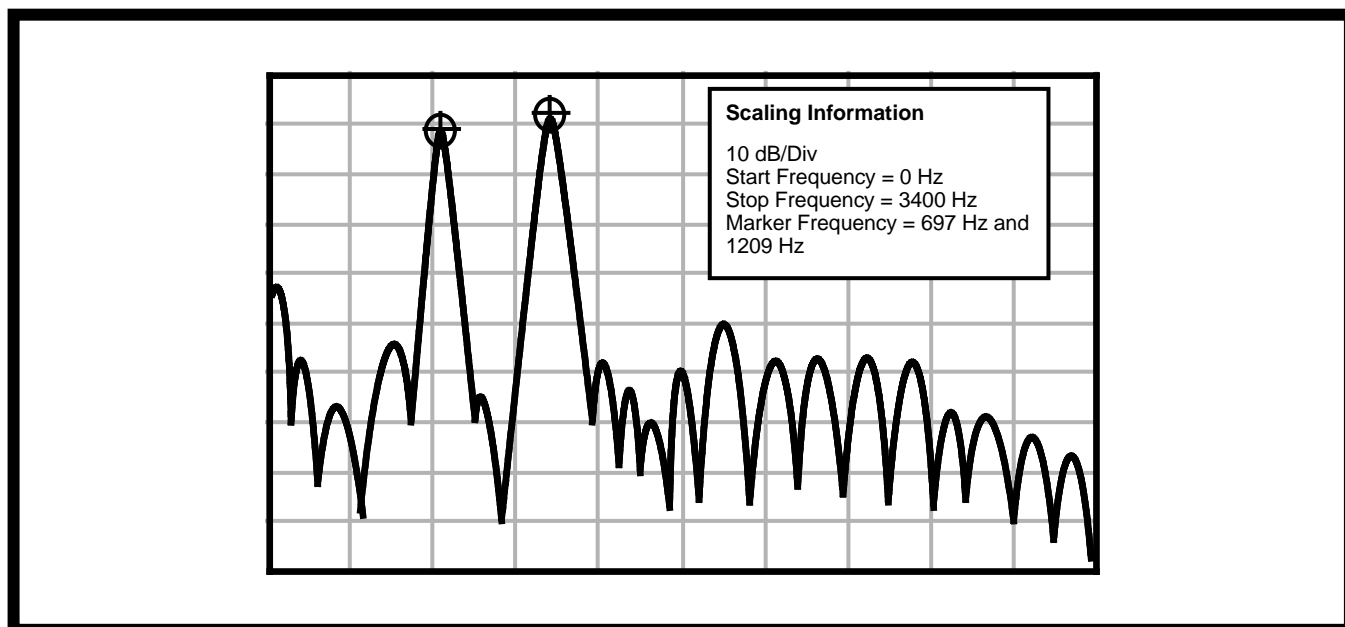

Figure 10 - Spectrum Plot

specify a DTMF signal, data conforming to the encoding format shown in Table 1 must be written to the transmit Data Register. Note that this is the same as the receiver output code. The individual tones which are generated (f_{LOW} and f_{HIGH}) are referred to as Low Group and High Group tones. As seen from the table, the low group frequencies are 697, 770, 852 and 941 Hz. The high group frequencies are 1209, 1336, 1477 and 1633 Hz. Typically, the high group to low group amplitude ratio (twist) is 2 dB to compensate for high group attenuation on long loops.

This code is used to specify a time segment length, which will ultimately determine the frequency of the tone. When the divider reaches the appropriate count, as determined by the input code, a reset pulse is issued and the counter starts again. The number of time segments is fixed at 32, however, by varying the segment length as described above the frequency can also be varied. The divider output clocks another counter, which addresses the sinewave lookup ROM.

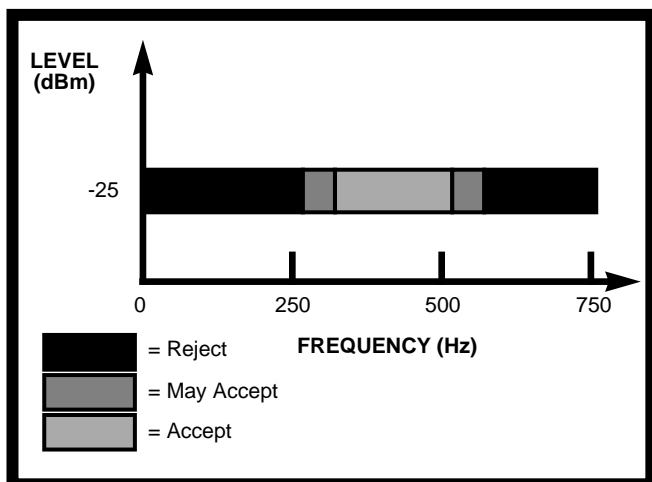

Figure 8 - Call Progress Response

The period of each tone consists of 32 equal time segments. The period of a tone is controlled by varying the length of these time segments. During write operations to the Transmit Data Register the 4 bit data on the bus is latched and converted to 2 of 8 coding for use by the programmable divider circuitry.

The lookup table contains codes which are used by the switched capacitor D/A converter to obtain discrete and highly accurate DC voltage levels. Two identical circuits are employed to produce row and column tones, which are then mixed using a low noise summing amplifier. A bandwidth limiting filter is incorporated and serves to attenuate distortion products above 8 kHz. It can be seen from Figure 10 that the distortion products are very low in amplitude.

Burst Mode

In certain telephony applications it is required that DTMF signals being generated are of a specific duration determined either by the particular application or by any one of the exchange transmitter specifications currently existing. Standard DTMF signal timing can be accomplished by making use of the Burst Mode. The transmitter is capable of issuing symmetric bursts/pauses of predetermined duration. This burst/pause duration is $51 \text{ ms} \pm 1 \text{ ms}$ which is a standard interval for autodialer and central office applications. After the burst/pause has been issued, the appropriate bit is set in the Status Register indicating that the transmitter is ready for more data.

The timing described above is available when DTMF mode has been selected. However, when CP mode (Call Progress mode) is selected, the burst/pause duration is doubled to 102 ms ±2 ms. Note that when CP mode and Burst mode have been selected, DTMF tones may be transmitted only and *not* received. In applications where a non-standard burst/pause time is desirable, a software timing loop or external timer can be used to provide the timing pulses when the burst mode is disabled by enabling and disabling the transmitter.

Single Tone Generation

A single tone mode is available whereby individual tones from the low group or high group can be generated. This mode can be used for DTMF test equipment applications, acknowledgment tone generation and distortion measurements. Refer to Control Register B description for details.

ACTIVE INPUT	OUTPUT FREQUENCY (Hz)		%ERROR
	SPECIFIED	ACTUAL	
L1	697	699.1	+0.30
L2	770	766.2	-0.49
L3	852	847.4	-0.54
L4	941	948.0	+0.74
H1	1209	1215.9	+0.57
H2	1336	1331.7	-0.32
H3	1477	1471.9	-0.35
H4	1633	1645.0	+0.73

Table 2. Actual Frequencies Versus Standard Requirements

Distortion Calculations

The MT88L89 is capable of producing precise tone bursts with minimal error in frequency (see Table 2). The internal summing amplifier is followed by a first-order lowpass switched capacitor filter to minimize harmonic components and intermodulation products. The total harmonic distortion for a *single tone* can be calculated using Equation 1, which is the ratio of the total power of all the extraneous frequencies to the power of the fundamental frequency expressed as a percentage.

$$THD (\%) = 100 \frac{\left(V_{2f}^2 + V_{3f}^2 + V_{4f}^2 + \dots + V_{nf}^2 \right)}{V_{\text{fundamental}}^2}$$

Equation 1. THD (%) For a Single Tone

The Fourier components of the tone output correspond to $V_{2f} \dots V_{nf}$ as measured on the output waveform. The total harmonic distortion for a *dual tone* can be calculated using Equation 2. V_L and V_H correspond to the low group amplitude and high group amplitude, respectively and V_{IMD}^2 is the sum of all the intermodulation components. The internal switched-capacitor filter following the D/A converter keeps distortion products down to a very low level as shown in Figure 10.

$$THD (\%) = 100 \frac{\left(V_{2L}^2 + V_{3L}^2 + \dots + V_{nL}^2 + V_{2H}^2 + V_{3H}^2 + \dots + V_{nH}^2 + V_{IMD}^2 \right)}{V_L^2 + V_H^2}$$

Equation 2. THD (%) For a Dual Tone

DTMF Clock Circuit

The internal clock circuit is completed with the additions of a standard television colour burst crystal. The crystal specification is as follows:

- Frequency: 3.579545 MHz
- Frequency Tolerance: ±0.1%
- Resonance Mode: Parallel
- Load Capacitance: 18pF
- Maximum Series Resistance: 150ohms
- Maximum Drive Level: 2mW

e.g. CTS Knights MP036S
Toyocom TQC-203-A-9S

A number of MT88L89 devices can be connected as shown in Figure 11 such that only one crystal is required. Alternatively, the OSC1 inputs on all devices can be driven from a CMOS buffer with the OSC2 outputs left unconnected.

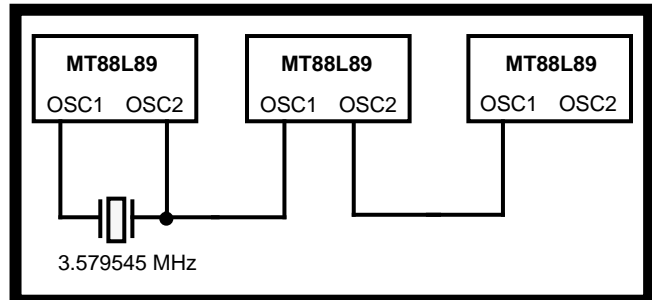

Figure 11 - Common Crystal Connection

Microprocessor Interface

The MT88L89 design incorporates an adaptive interface, which allows it to be connected to various kinds of microprocessors. Key functions of this interface include the following:

- Continuous activity on DS/RD is not necessary to update the internal status registers.
- Compatible with Motorola and Intel processors. Determines whether input timing is that of an Intel or Motorola controller by monitoring DS/RD, on the CS falling edge.
- Differentiates between multiplexed and non-multiplexed microprocessor buses. Address and data are latched in accordingly.

Figure 16 shows the timing diagram for the Motorola microcontrollers. The chip select (CS) input is formed by NANDing address strobe (AS) and address decode output. The MT88L89 examines the state of DS/RD on the falling edge of CS. For Motorola bus timing DS/RD must be low on the falling edge of CS. Figure 12(a) shows the connection of the MC68L11/MC68B11 Motorola processor to the MT88L89 DTMF transceiver.

Figures 17 and 18 are the timing diagrams for the Intel 8xL5x series (12 MHz) micro-controllers with

multiplexed address and data buses. The MT88L89 latches in the state of DS/RD on the falling edge of CS. When DS/RD is high, Intel processor operation is selected. By NANDing the address latch enable (ALE) output with the high-byte address (P2) decode output, CS can be generated. Figure 12(b) shows the connection of these Intel processors to the MT88L89 transceiver.

NOTE: The adaptive micro interface relies on high-to-low transition on CS to recognize the microcontroller interface. This pin must not be tied permanently low. Only one register access is allowed on any CS assertion.

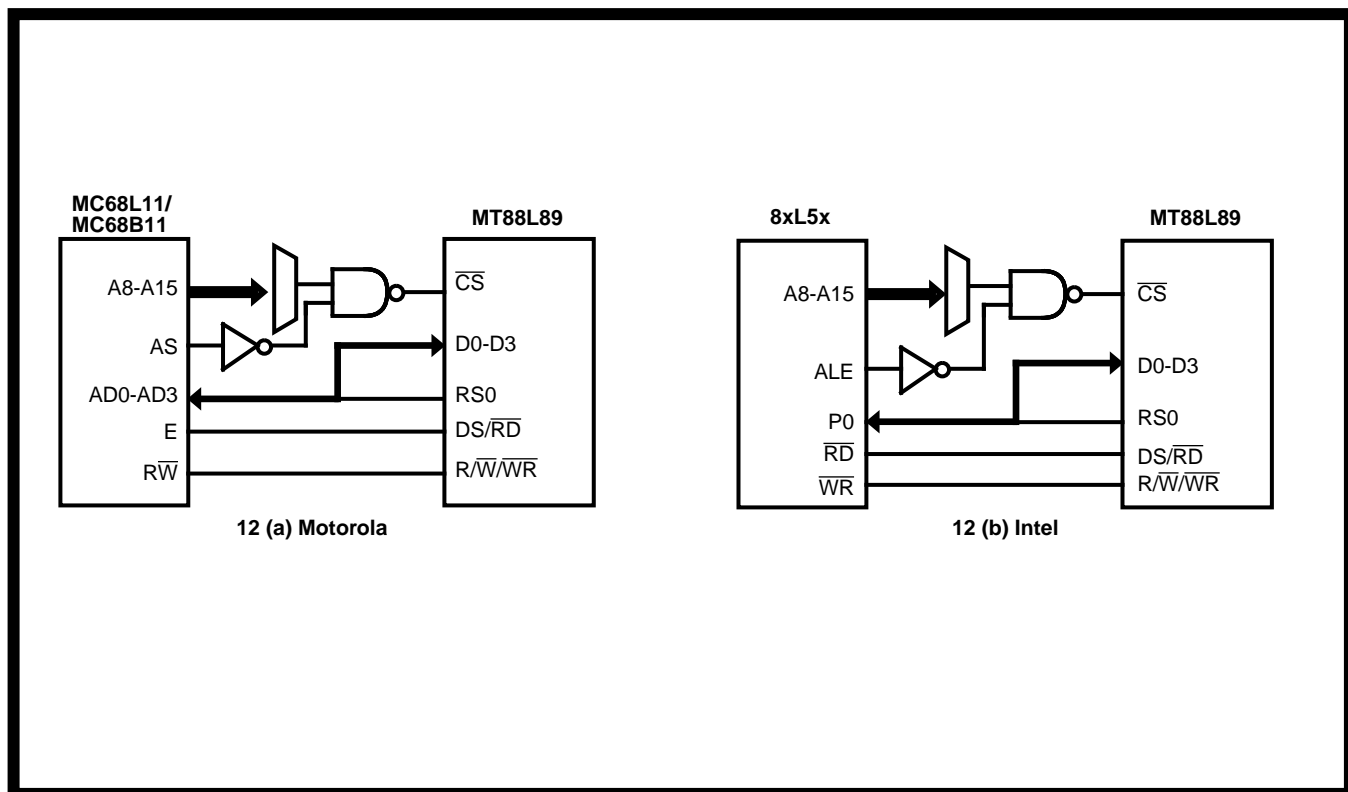

Figure 12 a) & b) - MT88L89 Interface Connections for Various Intel and Motorola Micros

The adaptive micro interface provides access to five internal registers. The read-only Receive Data Register contains the decoded output of the last valid DTMF digit received. Data entered into the write-only Transmit Data Register will determine which tone pair is to be generated (see Table 1 for coding details). Transceiver control is accomplished with two control registers (see Tables 6 and 7), CRA and CRB, which have the same address. A write operation to CRB is executed by first setting the most significant bit (b3) in CRA. The following write operation to the same address will then be directed to CRB, and subsequent write cycles will be directed back to CRA. The read-only status register indicates the current transceiver state (see Table 8).

RS0	Motorola	Intel		FUNCTION
	R \bar{W}	$\bar{W}R$	$\bar{R}D$	
0	0	0	1	Write to Transmit Data Register
0	1	1	0	Read from Receive Data Register
1	0	0	1	Write to Control Register
1	1	1	0	Read from Status Register

Table 3. Internal Register Functions

A software reset must be included at the beginning of all programs to initialize the control registers upon power-up or power reset (see Figure 14). Refer to Tables 4-7 for bit descriptions of the two control registers.

b3	b2	b1	b0
RSEL	IRQ	CP/ $\bar{D}TMF$	TOUT

Table 4. CRA Bit Positions

The multiplexed $\bar{I}RQ/CP$ pin can be programmed to generate an interrupt upon validation of DTMF signals or when the transmitter is ready for more data (burst mode only). Alternatively, this pin can be configured to provide a square-wave output of the call progress signal. The $\bar{I}RQ/CP$ pin is an open drain output and requires an external pull-up resistor (see Figure 13).

b3	b2	b1	b0
C/\bar{R}	S/\bar{D}	$\bar{R}xEN$	$\bar{BURST} ENABLE$

Table 5. CRB Bit Positions

BIT	NAME	DESCRIPTION
b0	TOUT	Tone Output Control. A logic high enables the tone output; a logic low puts the DTMF transmitter in power down mode. The TONE output pin is held in high impedance and the transmit register is cleared. See Note 1 below.
b1	CP/ $\bar{D}TMF$	Call Progress or DTMF Mode Select. A logic high enables the receive call progress mode; a logic low enables DTMF mode. In DTMF mode the device is capable of receiving and transmitting DTMF signals. In CP mode a rectangular wave representation of the received tone signal will be present on the $\bar{I}RQ/CP$ output pin if IRQ has been enabled (control register A, b2=1). In order to be detected, CP signals must be within the bandwidth specified in the AC Electrical Characteristics for Call Progress. Note: DTMF signals cannot be detected when CP mode is selected.
b2	IRQ	Interrupt Enable. A logic high enables the interrupt function; a logic low de-activates the interrupt function. When IRQ is enabled and DTMF mode is selected (control register A, b1=0), the $\bar{I}RQ/CP$ output pin will go low when either 1) a valid DTMF signal has been received for a valid guard time duration, or 2) the transmitter is ready for more data (burst mode only).
b3	RSEL	Register Select. A logic high selects control register B for the next write cycle to the control register address. After writing to control register B, the following control register write cycle will be directed to control register A.

Table 6. Control Register A Description

BIT	NAME	DESCRIPTION
b0	$\overline{\text{BURST}}$	<p>Burst Mode Select. A logic high de-activates burst mode; a logic low enables burst mode. When activated, the digital code representing a DTMF signal (see Table 1) can be written to the transmit register, which will result in a transmit DTMF tone burst and pause of equal durations (typically 51 msec). Following the pause, the status register will be updated (b1 - Transmit Data Register Empty), and an interrupt will occur if the interrupt mode has been enabled.</p> <p>When CP mode (control register A, b1) is enabled the normal tone burst and pause durations are extended from a typical duration of 51 msec to 102 msec.</p> <p>When $\overline{\text{BURST}}$ is high (de-activated) the transmit tone burst duration is determined by the TOUT bit (control register A, b0).</p>
b1	$\overline{\text{RxEN}}$	This bit enables the DTMF and Call Progress Tone receivers. A logic low enables both circuits. A logic high deactivates and puts both receiver circuits into power down mode. See Note 1 below.
b2	$\text{S}/\overline{\text{D}}$	Single or Dual Tone Generation. A logic high selects the single tone output; a logic low selects the dual tone (DTMF) output. The single tone generation function requires further selection of either the row or column tones (low or high group) through the $\text{C}/\overline{\text{R}}$ bit (control register B, b3).
b3	$\text{C}/\overline{\text{R}}$	Column or Row Tone Select. A logic high selects a column tone output; a logic low selects a row tone output. This function is used in conjunction with the $\text{S}/\overline{\text{D}}$ bit (control register B, b2).

Table 7. Control Register B Description

Note 1: When both TOUT and $\overline{\text{RxEN}}$ are asserted to power down, the crystal oscillator and the Vref circuits are powered down.

BIT	NAME	STATUS FLAG SET	STATUS FLAG CLEARED
b0	IRQ	Interrupt has occurred. Bit one (b1) or bit two (b2) is set.	Interrupt is inactive. Cleared after Status Register is read.
b1	TRANSMIT DATA REGISTER EMPTY (BURST MODE ONLY)	Pause duration has terminated and transmitter is ready for new data.	Cleared after Status Register is read or when in non-burst mode.
b2	RECEIVE DATA REGISTER FULL	Valid data is in the Receive Data Register.	Cleared after Status Register is read.
b3	$\overline{\text{DELAYED STEERING}}$	Set upon the valid detection of the absence of a DTMF signal.	Cleared upon the detection of a valid DTMF signal.

Table 8. Status Register Description

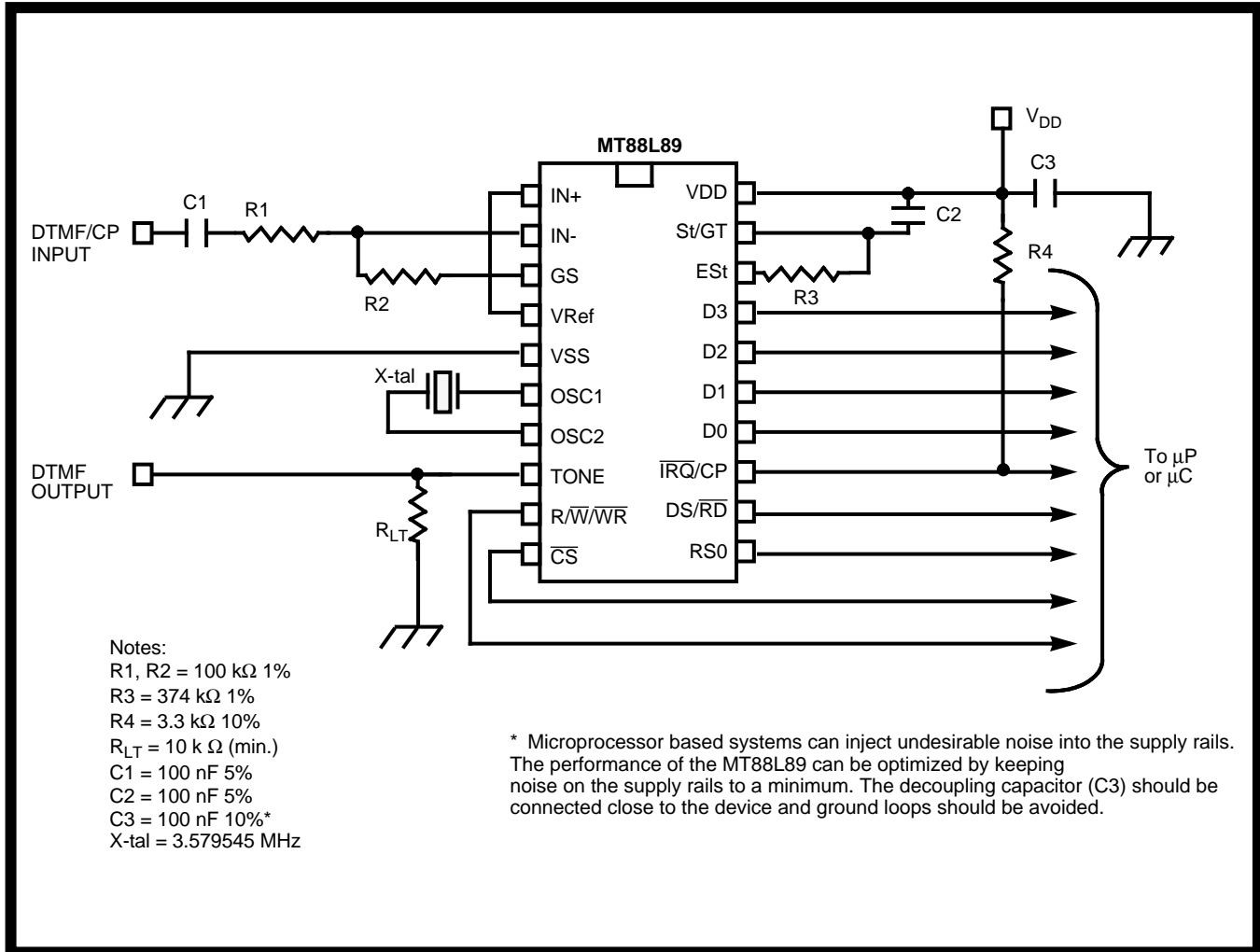

Figure 13 - Application Circuit (Single-Ended Input)

INITIALIZATION PROCEDURE

A software reset must be included at the beginning of all programs to initialize the control registers after power up.

Description:

	<u>Motorola</u>		<u>Intel</u>		<u>Data</u>			
	RS0	R/W	WR	RD	b3	b2	b1	b0
1) Read Status Register	1	1	1	0	X	X	X	X
2) Write to Control Register	1	0	0	1	0	0	0	0
3) Write to Control Register	1	0	0	1	0	0	0	0
4) Write to Control Register	1	0	0	1	1	0	0	0
5) Write to Control Register	1	0	0	1	0	0	0	0
6) Read Status Register	1	1	1	0	X	X	X	X

TYPICAL CONTROL SEQUENCE FOR BURST MODE APPLICATIONS

Transmit DTMF tones of 50 ms burst/50 ms pause and Receive DTMF Tones.

Sequence:

	RS0	R/W	WR	RD	b3	b2	b1	b0
1) Write to Control Register A (tone out, DTMF, IRQ, Select Control Register B)	1	0	0	1	1	1	0	1
2) Write to Control Register B (burst mode)	1	0	0	1	0	0	0	0
3) Write to Transmit Data Register (send a digit 7)	0	0	0	1	0	1	1	1
4) Wait for an Interrupt or Poll Status Register								
5) Read the Status Register	1	1	1	0	X	X	X	X
-if bit 1 is set, the Tx is ready for the next tone, in which case...								
Write to Transmit Register (send a digit 5)	0	0	0	1	0	1	0	1
-if bit 2 is set, a DTMF tone has been received, in which case....								
Read the Receive Data Register	0	1	1	0	X	X	X	X
-if both bits are set...								
Read the Receive Data Register	0	1	1	0	X	X	X	X
Write to Transmit Data Register	0	0	0	1	0	1	0	1

NOTE: IN THE TX BURST MODE, STATUS REGISTER BIT 1 WILL NOT BE SET UNTIL 100 ms (± 2 ms) AFTER THE DATA IS WRITTEN TO THE TX DATA REGISTER. IN EXTENDED BURST MODE THIS TIME WILL BE DOUBLED TO 200 ms (± 4 ms)

Figure 14 - Application Notes

Absolute Maximum Ratings*

	Parameter	Symbol	Min	Max	Units
1	Power supply voltage $V_{DD}-V_{SS}$	$V_{DD}-V_{SS}$		5.5	V
2	Voltage on any pin	V_I	$V_{SS}-0.3$	$V_{DD}+0.3$	V
3	Current at any pin (Except V_{DD} and V_{SS})			10	mA
4	Storage temperature	T_{ST}	-65	+150	°C
5	Package power dissipation	P_D		1000	mW

* Exceeding these values may cause permanent damage. Functional operation under these conditions is not implied.

Recommended Operating Conditions - Voltages are with respect to ground (V_{SS}) unless otherwise stated.

	Parameter	Sym	Min	Typ [‡]	Max	Units	Test Conditions
1	Positive power supply	V_{DD}	2.7	3	3.6	V	
2	Operating temperature	T_O	-40		+85	°C	
3	Crystal clock frequency	f_{CLK}	3.575965	3.579545	3.583124	MHz	

‡ Typical figures are at 25 °C and for design aid only; not guaranteed and not subject to production testing.

DC Electrical Characteristics [†] - $V_{SS}=0V$.

		Characteristics	Sym	Min	Typ [‡]	Max	Units	Test Conditions
1	S U P P L Y	Standby supply current	I_{DDQ}		1.0	10.0	μA	TOUT and RxEN bits asserted to power down mode
2		Transmitter supply current	I_{DDTX}		2.0	5.0	mA	Transmitter fully enabled and \overline{RxEN} bit asserted to power down mode
3		Receiver supply current	I_{DDRX}		3.0	7.0	mA	Receiver fully enabled and TOUT bit asserted to power down mode
4		Operating supply current	I_{DD}		3.1	7.0	mA	Device fully enabled
5	I N P U T S	High level input voltage (OSC1)	V_{IHO}	$0.7 V_{DD}$			V	
6		Low level input voltage (OSC1)	V_{ILO}			$0.3 V_{DD}$	V	
7		Steering threshold voltage	V_{Tst}	$0.43 V_{DD}$		$0.51 V_{DD}$	V	
8	O U T P U T S	Low level output voltage (OSC2)	V_{OLO}			$0.1 V_{DD}$	V	No load
9		High level output voltage (OSC2)	V_{OHO}	$0.9 V_{DD}$			V	No load
10		Output leakage current (IRQ) (Tone)	I_{OZT}		1	10	μA	
11		V_{Ref} output voltage	V_{Ref}	$0.47 V_{DD}$		$0.53 V_{DD}$	V	No load
12		V_{Ref} output resistance	R_{OR}			2.5	kΩ	Note 9
13	D i g i t a l	Low level input voltage	V_{IL}			$0.3 V_{DD}$	V	
14		High level input voltage	V_{IH}	$0.7 V_{DD}$			V	
15		Input leakage current	I_{IZ}			10	μA	$V_{IN}=V_{SS}$ to V_{DD}
16		Output high impedance	I_{OZD}			10	μA	$V_{IN}=V_{SS}$ to V_{DD}

DC Electrical Characteristics (continued)[†] - $V_{SS}=0V$.

		Characteristics	Sym	Min	Typ [‡]	Max	Units	Test Conditions
17	Data	Source current	I_{OHD}	1.0	3.8		mA	$V_{OH}=0.9V_{DD}$
18	Bus	Sink current	I_{OLD}	1.5	4.0		mA	$V_{OL}=0.1V_{DD}$
19	ES _t and S _t /GT	Source current	I_{OHE}	0.5	2.8		mA	$V_{OH}=0.9V_{DD}$
20		Sink current	I_{OLE}	1.5	4		mA	$V_{OL}=0.1V_{DD}$
21	IRQ/ CP	Sink current	I_{OLI}	0.7	9		mA	$V_{OL}=0.1V_{DD}$

[†] Characteristics are over recommended operating conditions unless otherwise stated.

[‡] Typical figures are at 25 °C, $V_{DD}=3V$ and for design aid only: not guaranteed and not subject to production testing.

* See "Notes" following AC Electrical Characteristics Tables.

Electrical Characteristics**Gain Setting Amplifier** - Voltages are with respect to ground (V_{SS}) unless otherwise stated, $V_{SS}=0V$, $V_{DD}=3V$, $T_O=25^\circ C$.

		Characteristics	Sym	Min	Typ [‡]	Max	Units	Test Conditions
1		Input leakage current	I_{IN}			100	nA	$V_{SS} \leq V_{IN} \leq V_{DD}$
2		Input resistance	R_{IN}	10			M Ω	Note 9
3		Input offset voltage	V_{OS}			25	mV	Note 9
4		Power supply rejection	PSRR	50			dB	1 kHz, See Note 9
5		Common mode rejection	CMRR	40			dB	$V_{SS} + 0.75V \leq V_{IN} \leq V_{DD} - 0.75V$ biased at $V_{REF} = 1.5V$ Note 9
6		DC open loop voltage gain	A_{VOL}	32			dB	Note 9
7		Unity gain bandwidth	f_c	0.3			MHz	Note 9
8		Output voltage swing	V_O	2.2			V_{pp}	$R_{LGS} \geq 100 k\Omega$ to V_{SS} at GS, 3KHz Note 9
9		Allowable capacitive load (GS)	C_{LGS}			100	pF	Note 9
10		Allowable resistive load (GS)	R_{LGS}	50			k Ω	Note 9
11		Common mode range	V_{CM}		1.5		V_{pp}	$V_{DD} = 3V$, No Load Note 9

[‡] Typical figures are at 25°C and for design aid only: not guaranteed and not subject to production testing.

MT88L89 AC Electrical Characteristics[†] - Voltages are with respect to ground (V_{SS}) unless otherwise stated.

		Characteristics	Sym	Min	Typ [‡]	Max	Units	Notes*	
1	R X	Valid input signal levels (each tone of composite signal)		-34		-4	dBm	1,2,3,5,6 min @ $V_{DD}=3.6V$ max @ $V_{DD}=2.7V$	
				15.4		489	mV _{RMS}	1,2,3,5,6	
2	R X	Positive twist accept				8	dB	2,3,6,9	
3		Negative twist accept				8	dB	2,3,6,9	
4		Freq. deviation accept		$\pm 1.5\% \pm 2Hz$				2,3,5	
5		Freq. deviation reject		$\pm 3.5\%$				2,3,5	
6		Third tone tolerance					-16	dB	2,3,4,5,9,10
7		Noise tolerance					-12	dB	2,3,4,5,7,9,10
8		Dial tone tolerance				22		dB	2,3,4,5,8,9

[†] Characteristics are over recommended operating conditions unless otherwise stated.

[‡] Typical figures are at 25°C, $V_{DD} = 3V$, and for design aid only: not guaranteed and not subject to production testing.

* See "Notes" following AC Electrical Characteristics Tables.

AC Electrical Characteristics[†]- Call Progress - Voltages are with respect to ground (V_{SS}), unless otherwise stated.

	Characteristics	Sym	Min	Typ [‡]	Max	Units	Conditions
1	Accept Bandwidth	f_A	310		500	Hz	@ -25 dBm Note 9
2	Lower freq. (REJECT)	f_{LR}			290	Hz	@ -25 dBm Note 9
3	Upper freq. (REJECT)	f_{HR}	540			Hz	@ -25 dBm Note 9
4	Call progress tone detect level (total power)		-30			dBm	

[†] Characteristics are over recommended operating conditions unless otherwise stated

[‡] Typical figures are at 25°C, $V_{DD}=3V$, and for design aid only: not guaranteed and not subject to production testing

AC Electrical Characteristics † - Voltages are with respect to ground (V_{SS}), unless otherwise stated.

		Characteristics	Sym	Min	Typ [‡]	Max	Units	Conditions	
1	T O N E I N	Tone present detect time	t_{DP}	5	11	14	ms	Note 11	
2		Tone absent detect time	t_{DA}	0.5	4	8.5	ms	Note 11	
3		Delay St to b3	t_{PSb3}			20	μ s	Figure 7, Note 9	
4		Delay St to RX ₀ -RX ₃	t_{PSIRX}			11	μ s	Figure 7, Note 9	
5	T O N E O U T	Tone burst duration	t_{BST}	50		52	ms	DTMF mode	
6		Tone pause duration	t_{PS}	50		52	ms	DTMF mode	
7		Tone burst duration (extended)	t_{BSTE}	100		104	ms	Call Progress mode	
8		Tone pause duration (extended)	t_{PSE}	100		104	ms	Call Progress mode	
9		High group output level	V_{HOUT}	-17.3		-13.3	dBm	$R_L=10k\Omega$	
10		Low group output level	V_{LOUT}	-19.3		-15.3	dBm	$R_L=10k\Omega$	
11		Pre-emphasis	dB _P		2	3	dB	$R_L=10k\Omega$	
12		Output distortion (Single Tone)	THD			-35	dB	25 kHz Bandwidth	
13								$R_L=10k\Omega$, Note 9	
14		Frequency deviation	f_D		± 0.7	± 1.5	%	$f_C=3.579545$ MHz	
15		Output load resistance	R_{LT}	10		50	k Ω	Note 9	
16		X T A L	Crystal/clock frequency	f_C	3.5759	3.5795	3.5831	MHz	Note 9
17			Clock input rise and fall time	t_{CLRF}			110	ns	Ext. clock, Note 9
18			Clock input duty cycle	DC _{CL}	40	50	60	%	Ext. clock, Note 9
19			OSC2 load capacitance	C_{LO}			30	pF	
20	Oscillator start-up time		t_{OST}			10	ms	Note 9	

† Timing is over recommended temperature & power supply voltages.

‡ Typical figures are at 25°C and for design aid only: not guaranteed and not subject to production testing.

AC Electrical Characteristics†- MPU Interface - Voltages are with respect to ground (V_{SS}), unless otherwise stated.

	Characteristics	Sym	Min	Typ‡	Max	Units	Conditions
1	$\overline{RD}/\overline{WR}$ low pulse width	t_{CL}	200	400		ns	Figure 15, Note 12 $t_{CL} + t_{CH} \geq 1000ns$
2	DS high pulse width	t_{CH}	200	400		ns	Figure 15, Note 12 $t_{CL} + t_{CH} \geq 1000ns$
3	Rise and fall time all digital inputs	t_R, t_F			20	ns	Figure 15
4	R/\overline{W} setup time	t_{RWS}	23			ns	Figures 16 & 17
5	R/\overline{W} hold time	t_{RWH}	26			ns	Figures 16 & 17
6	Address setup time (RS0)	t_{AS}	0			ns	Figures 16 - 19
7	Address hold time (RS0)	t_{AH}	45			ns	Figures 16 - 19
8	Data hold time (read)	t_{DHR}	22			ns	Figures 16 - 19
9	DS/ \overline{RD} to valid data delay (read)	t_{DDR}			125	ns	Figures 16 - 19
10	Data setup time (write)	t_{DSW}	60			ns	Figures 16 - 19
11	Data hold time (write)	t_{DHW}	10			ns	Figures 16 - 19
12	Chip select setup time	t_{CSS}	45			ns	Figures 16 - 19
13	Chip select hold time	t_{CSH}	10			ns	Figures 16 - 19
14	DS/ \overline{RD} set up time prior to \overline{CS} assertion	t_{RDS}, t_{DSS}	20			ns	

† Characteristics are over recommended operating conditions unless otherwise stated

‡ Typical figures are at 25°C, $V_{DD}=3V$, and for design aid only: not guaranteed and not subject to production testing

- NOTES:**
- 1) dBm=decibels above or below a reference power of 1 mW into a 600 ohm load.
 - 2) Digit sequence consists of all 16 DTMF tones.
 - 3) Tone duration=40 ms. Tone pause=40 ms.
 - 4) Nominal DTMF frequencies are used.
 - 5) Both tones in the composite signal have an equal amplitude.
 - 6) The tone pair is deviated by $\pm 1.5\% \pm 2$ Hz.
 - 7) Bandwidth limited (3 kHz) Gaussian noise.
 - 8) The precise dial tone frequencies are 350 and 440 Hz ($\pm 2\%$).
 - 9) Guaranteed by design and characterization. Not subject to production testing.
 - 10) Referenced to the lowest amplitude tone in the DTMF signal.
 - 11) For guard time calculation purposes.
 - 12) Operation of microprocessor interface requires that $t_{CL} + t_{CH} \geq 1000ns$

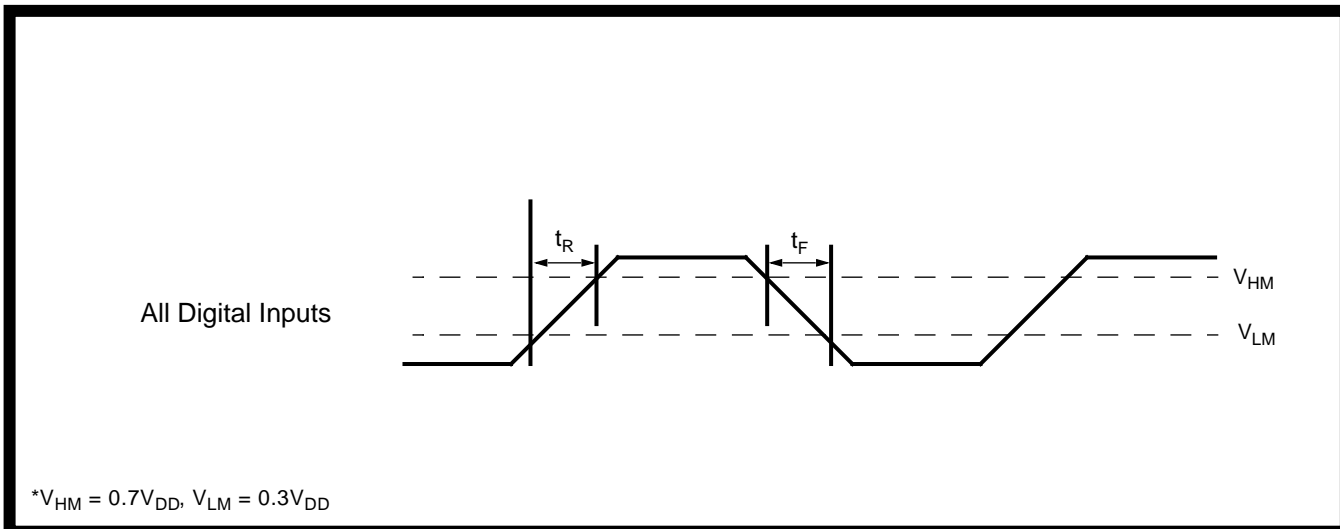

Figure 15 - Digital Signal Input Rise/Fall Times

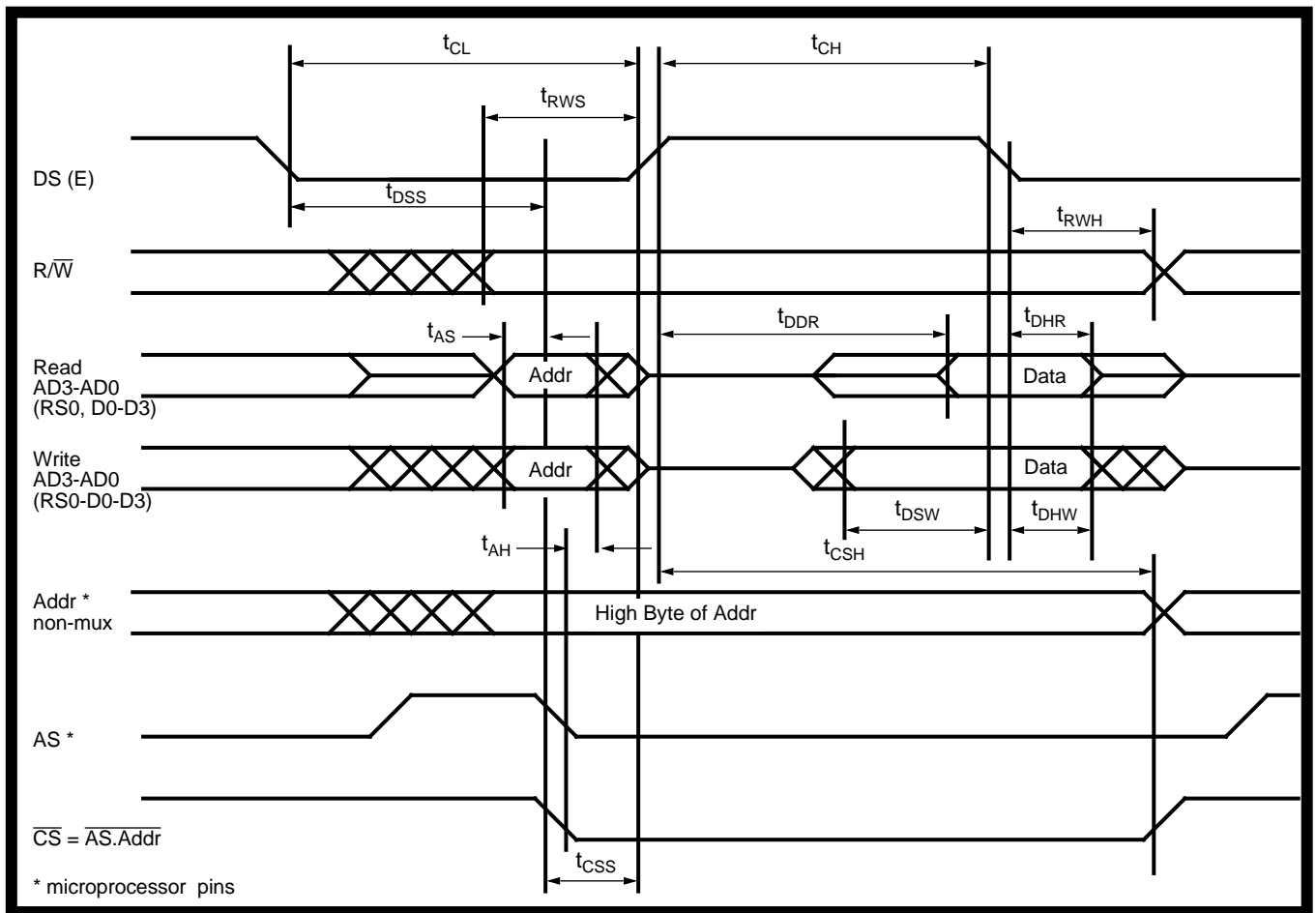

Figure 16 - Motorola BUS Timing Diagram

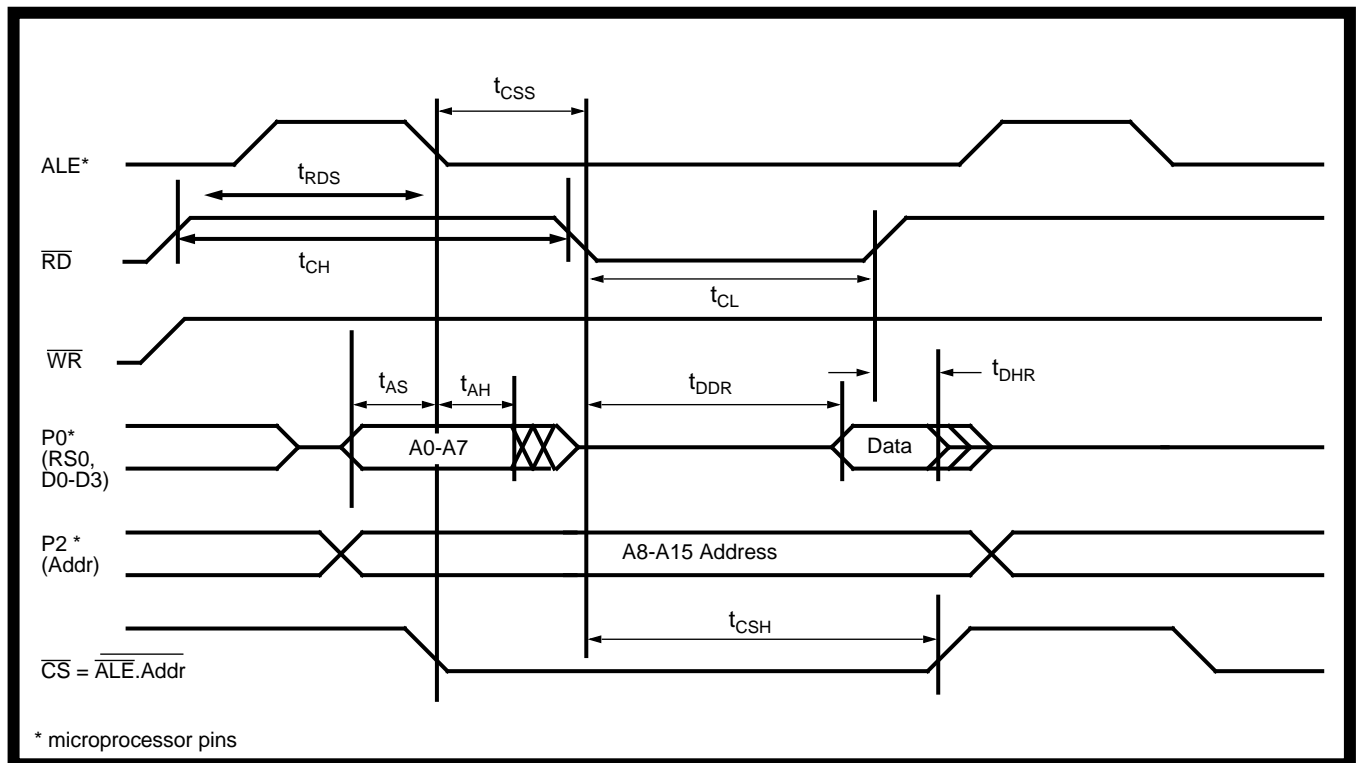

Figure 17 - Intel Read Timing Diagram

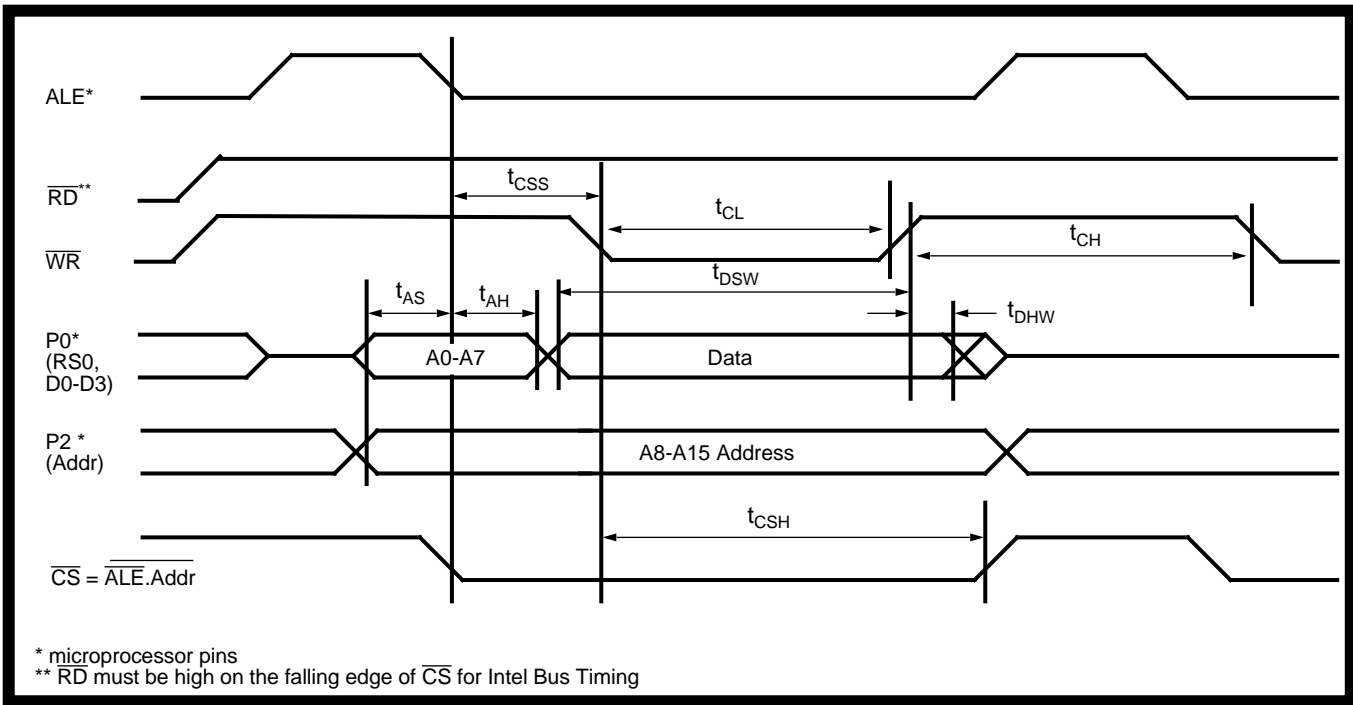

Figure 18 - Intel Write Timing Diagram